

# Specifications

## CityCat 1000

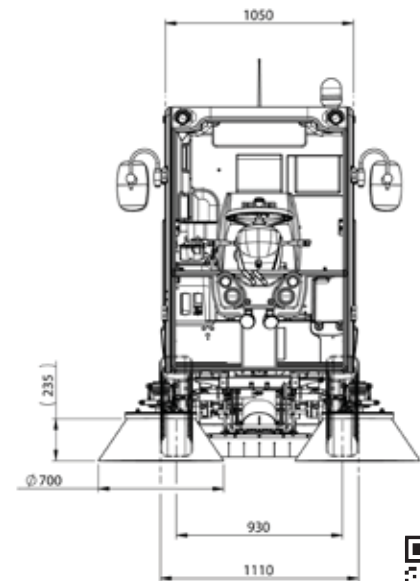
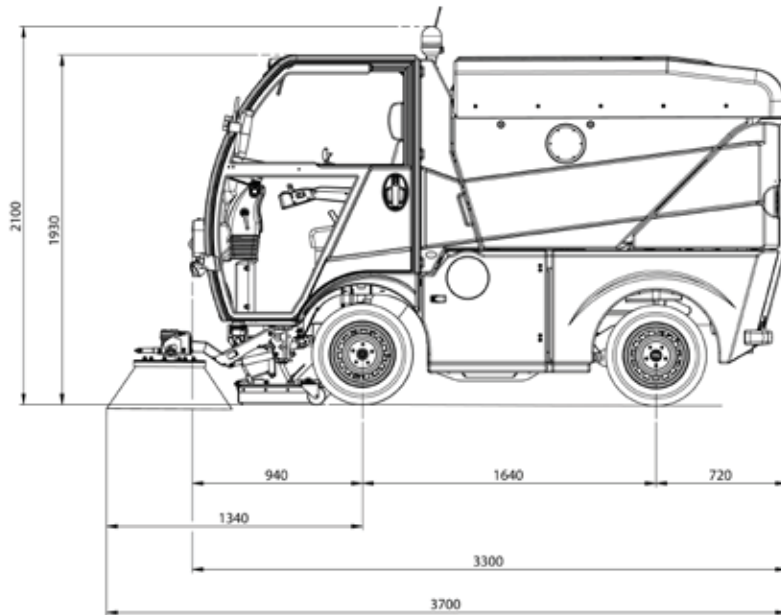

المعرفة كل جديد... اسكن الباركود  
To Know All New scan that barcode

[www.rem-ksa.com](http://www.rem-ksa.com)

## Small Sweeper - CityCat 1000

### Dimensions

Length	3300 mm
Length (2 brushes)	3700 mm
Width	1050 mm
Width (over wheels)	1110 mm
Height	1930 mm
Wheelbase	1640 mm
Track (front/rear)	930 mm
Sweeping path up to	2250 mm

### Weight

Unladen weight w/o driver and accessories	1800 kg
Payload	600 kg
GVWR	2400 kg

### Engine

Low-emission 3-cylinder Deutz D2011L03i diesel engine, Euromot III/A, 2330 cc, 31.2 kW / 43 HP @ 2300 rpm.

Fuel tank	50 l
Electrical system	12 V
Battery	74 Ah

### Transmission

Infinitely variable, hydraulically controlled hydrostatic transmission.

### Travel speed

Sweeping speed	0-12 km/h
Transit speed	0-25 km/h
Gradeability	25 %

### Hydraulic system

Gear pump for fan drive. Gear pump for hydraulic motion control systems, steering and brush drive.

### Axles and steering

Front drive axle with hydraulic differential. Load-sensing hydraulic front-wheel steering. Optional 4-wheel steering for maximum manoeuvrability and directional stability.

### Brakes

Hydraulic single-circuit braking system with rear drum brakes. Parking brake on rear axle.



**Wanderhose**

The exceptionally lightweight flexible suction hose picks up leaves and other debris effortlessly from all those hard-to-reach areas.



**Four-wheel steering**

Four-wheel steering provides maximum manoeuvrability and directional stability.

**Chassis**

Welded chassis. Front and rear suspension. Coil spring suspension and shock absorbers on the front axle. Double cone spring rear suspension.

**Tyres** 165 / 70 R13C

**Cab**

Comfortable, soundproofed cab mounted on hydraulic mounts. Windscreen made of heat-insulating, curved, low-reflection safety glass. Electrically heated windscreen. Doors with sliding windows. Heater with multi-speed fan. Sun visor. Windscreen wiper and washer. Comfortable, fully adjustable air suspension driver's seat. Adjustable steering column.

**Controls**

Clearly and ergonomically arranged controls and instrumentation. Comfortable armrest with integrated controls for sweeping functions. Temperature and fluid level gauges with warning system.

**Pick-up system**

Suction system with suction nozzle mounted between / in front of the front wheels and high performance suction fan.

**Hopper**

Chromium steel hopper, capacity 1<sup>3</sup>m  
hydraulic tipping  
Dump height up to 1350 mm  
Dump width 990 mm

**Water system**

Clean water tank 220 l  
Water recirculation system in the hopper for an additional 70 l

Electrically controlled water pump for water spray jets.

**Brushes**

2 brushes Ø 700 mm  
Infinitely variable speed control 0-100 rpm

Infinitely variable hydraulic brush pressure adjustment.



شركة مصنع آليات النظافة  
Refuse Equipment MFG. Co.